

CLEGHORN WARING CW289A

CYLINDER THERMOSTAT

For use with water storage heaters (calorifiers) fitted to **direct-cooled** marine engines

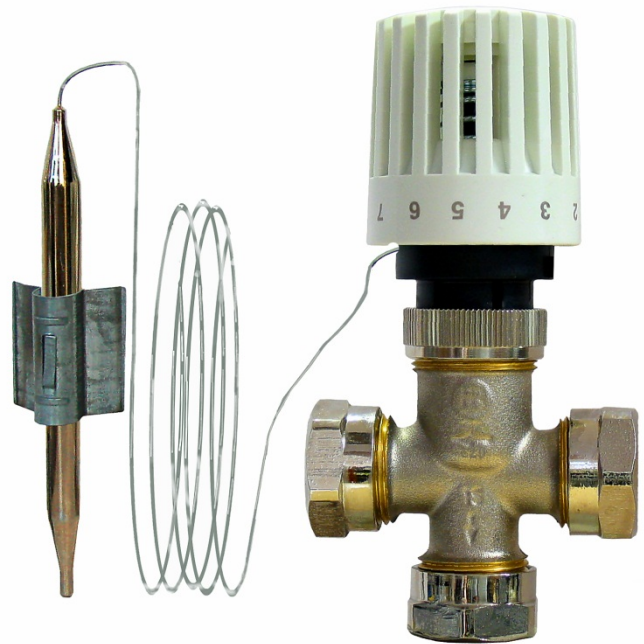

DESCRIPTION

CW289A Cylinder Thermostat is an automatic valve with remote temperature sensor. Fitted to a C-WARM marine water storage heater (calorifier) it limits the temperature of the stored hot water to a pre-set maximum (normally 55°C) by restricting the flow of engine cooling water through the coil.

TYPICAL APPLICATION

CW289A is for use with **direct-cooled** marine engines, with the engine and the heating coil in series in the engine cooling circuit. The by-pass enables the flow of water through the coil to be restricted without reducing the cooling flow through the engine (For indirect-cooled engines, use CW276A Cylinder thermostat).

OPERATION

The sensor is attached to the copper wall of the C-WARM heater. A rise in temperature causes the liquid in the sensor to expand, forcing it through the capillary tubing connecting the sensor to the valve, and progressively actuating the valve. The flow of hot water from the engine cooling circuit is diverted from the coil into the by-pass, restricting the stored water temperature to its pre-set maximum.

POSITION

VERTICAL HEATERS

The sensor should be positioned 1/3 of the way up from the bottom of the cylinder, and well away from any other fittings.

HORIZONTAL HEATERS

Mount the sensor horizontally as shown

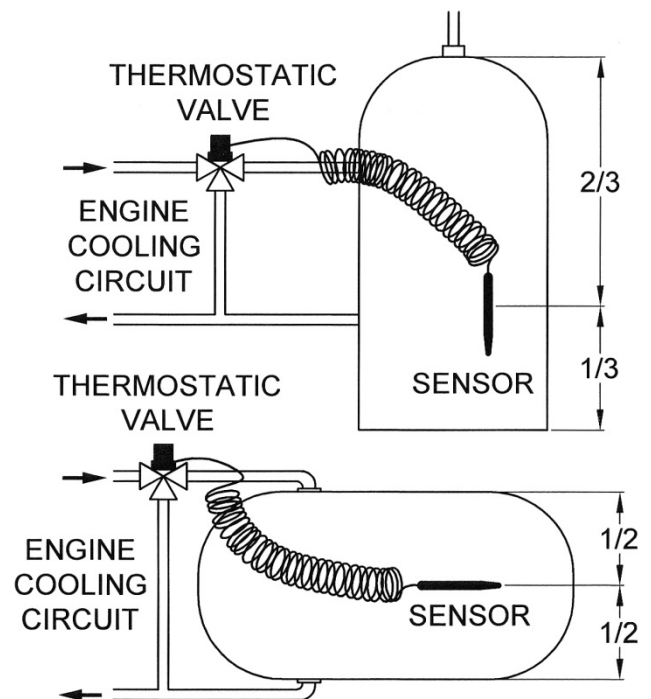

CW289A CYLINDER THERMOSTAT

INSTALLATION

1. Cut away the foam insulation from the cylinder wall to allow the sensor to sit against the cylinder wall. Do not remove more insulation than is necessary.
2. Fit the sensor and holder onto the tank and strap them both into position using the metal strap and screw clamps provided. The metal strap clamp should be positioned away from the sensor.
3. If necessary, put a suitable piece of padding material over the sensor to hold it firmly in place beneath the strap.

CAUTION!

*Take care not to damage the capillary tubing.
Avoid bending it sharply or repeatedly*

ASSEMBLY

Remove the black plastic cap from the valve body. Fit the control knob and tighten the screw connection. Connect the valve into the engine cooling circuit. Check that the direction of flow corresponds to the arrow on the valve body. The valve is supplied with compression fittings suitable for 15mm pipe, over which hose can be secured with clips. If preferred, the compression fittings can be discarded, and ½" BSP internal threaded connectors used instead.

COMMISSIONING

The valve may be set to close at temperatures between 30° and 70°C. Set the temperature to 55°C initially then adjust to obtain an acceptable stored water temperature. Allow sufficient time for the stored water temperature to change before making further adjustments.

